

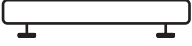

EN Accessories | Pedestal



M6WHBP01

902980371

Subject to change without notice.

CONTENTS

1. QR CODE.....	3
2. ACCESSORY OVERVIEW.....	5
3. BEFORE INSTALLATION.....	5
4. INSTALLING THE ACCESSORY.....	5
5. GUARANTEE	7
6. ENVIRONMENTAL CONCERNS.....	7

1. QR CODE



electrolux.com/manual/pedestalbuiltin



EN Read instructions before installation for important safety warnings and tips.
Scan the QR code to access full user manual in local language.

BG За важни предупреждения и съвети за безопасност, прочетете инструкциите преди инсталирането.
Сканирайте QR кода, за да получите достъп до пълното ръководство за потребителя на местния език.

CZ Před instalací si přečtete pokyny, které obsahují důležitá bezpečnostní varování a tipy.
Oskenováním QR kódu získáte přístup ke kompletní uživatelské příručce v místním jazyce.

DE Lesen Sie vor der Installation die Anleitung durch und machen Sie sich mit wichtigen Warnhinweisen und Tipps vertraut.
Scannen Sie den QR-Code, um auf das vollständige Benutzerhandbuch in lokaler Sprache zuzugreifen.

DK Læs anvisningerne før installation for vigtige sikkerhedsadvarsler og tips.
Scan QR-koden for at få adgang til hele brugsanvisningen på dit lokale sprog.

NO Les instruksjonene før montering for viktige sikkerhetsadvarsler og tips.
Skann QR-koden for å få tilgang til hele brukerhåndboken på det lokale språket.

ES Lea las instrucciones antes de la instalación para ver consejos y conocer advertencias de seguridad importantes.
Escanee el código QR para acceder al manual de usuario completo en local.

ET Lugege enne paigaldust ohutusjuhustest olulisi hoiatusi ohutuse kohta ja nõuandeid.
Kohalikus keeles kasutusjuhendile juurdepääsuks skaneerige QR-kood.

FI Lue ohjeiden sisältämät tärkeät turvallisuusvaroitukset ja -vinkit ennen asennusta.
Pääset lukemaan käyttöopasta kokonaisuudessaan paikallisella kielellä lukemalla QR-koodin.

FR Lisez les instructions avant l'installation pour prendre connaissance des avertissements et des conseils de sécurité importants.
Scannez le code QR pour accéder au manuel d'utilisation complet dans votre langue.

GR Διαβάστε τις οδηγίες πριν από την εγκατάσταση για σημαντικές προειδοποιήσεις και συμβουλές ασφαλείας.
Σαρώστε τον κωδικό QR για να έχετε πρόσβαση σε ολόκληρο το εγχειρίδιο χρήστη στην τοπική γλώσσα.

HU Telepítés előtt olvassa el az utasításokat a fontos biztonsági figyelmeztetések és tippel megismeréséhez.
Olvassa be a QR-kódot a teljes felhasználói kézikönyv helyi nyelven történő eléréséhez.

LV Pirms uzstādīšanas izlasiet norādes par svarīgiem drošības brīdinājumiem un ieteikumiem.
Noskenējiet QR kodu, lai piekļūtu pilnai lietotāja rokasgrāmatai vietējā valodā.

LT Prieš montuodami perskaitykite instrukciją, kurioje pateikti svarbūs saugos įspėjimai ir patarimai. Nuskaitykite QR kodą ir gaukite visą naudotojo vadovą vietine kalba.

NL Lees de instructies voor de installatie voor belangrijke veiligheidsaanschuwingen en tips. Scan de QR-code om toegang te krijgen tot de volledige gebruikershandleiding in de lokale taal.

PL Przed instalacją należy zapoznać się z instrukcją, w której znajdują się ważne wskazówki i ostrzeżenia dotyczące bezpieczeństwa. Aby uzyskać dostęp do pełnej instrukcji obsługi w miejscowym języku, należy zeskanować kod QR.

PT Leia as instruções antes da instalação para ver avisos de segurança e sugestões importantes. Efetue a leitura do código QR para aceder ao manual do utilizador completo no idioma local.

RO Citiți instrucțiunile înainte de instalare pentru avertismente și recomandări importante privind siguranța. Scanați codul QR pentru a accesa manualul complet al utilizatorului în limba locală.

RU Перед установкой и началом использования ознакомьтесь с важными указаниями по технике безопасности. Вы всегда можете найти и загрузить инструкцию по эксплуатации на русском языке отсканировав QR код, напечатанный на стр.2.

SE Läs anvisningarna före installationen för viktiga säkerhetsvarningar och tips. Skanna QR-koden för att få åtkomst till hela användarhandboken på lokalt språk.

SK Pred inštaláciou si prečítajte pokyny pre dôležité bezpečnostné upozornenia a tipy. Naskenovaním QR kódu získate prístup k celému návodu na používanie v miestnom jazyku.

SL Pred namestitvijo preberite navodila za pomembna varnostna opozorila in nasvete. Skenirajte QR kodo za dostopanje do celotnih navodil za uporabo v lokalnem jeziku.

TR Önemli güvenlik uyarıları ve ipuçları için montaja başlamadan talimatları okuyun. Yerel dilde kapsamlı kullanıcı kılavuzuna ulaşmak için QR kodunu tarayın.

UA Прочитайте інструкції перед встановленням, щоб дізнатися про важливі попередження та поради щодо техніки безпеки. Відскануйте QR-код, щоб отримати доступ до повної інструкції з експлуатації місцевою мовою.

IT Leggi le istruzioni prima dell'installazione per importanti avvertenze e suggerimenti sulla sicurezza. Esegui la scansione del codice QR per accedere al manuale utente completo nella lingua locale.

2. ACCESSORY OVERVIEW

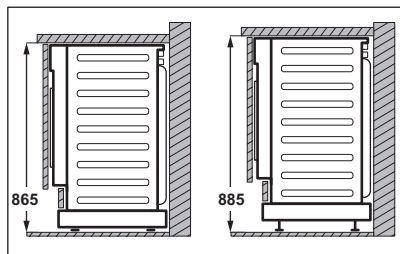

The installed accessory allows to adjust system height from minimum 865mm to the maximum 885mm.

WARNING!

This accessory is meant only for the Built In machine.

3. BEFORE INSTALLATION

3.1 Be prepared for installation

WARNING!

It is strongly recommended that this action is carried by two person.

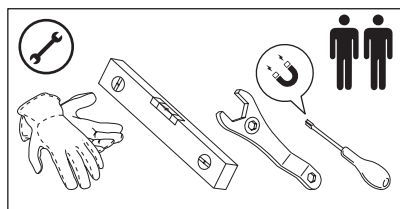

WARNING!

Before proceeding with installation, make sure there is enough room.

3.2 Verify box content.

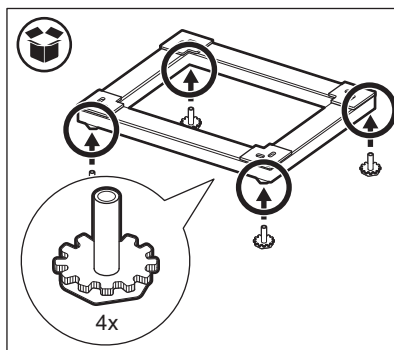

i

Box contains each 4 screws for washing machine and wash-dryer.

4. INSTALLING THE ACCESSORY

1. Extract the pedestal and all accessories from the box.
2. **If you install the pedestal under a brand new appliance**, unpack the appliance as indicated in the instructions supplied with it and then proceed with step 6.

i

Do not remove the transit bolts.

3. If the **appliance is already connected**:

- Disconnect the main plug from the mains socket.
 - Close the water tap.
 - Disconnect the inlet hose from the water tap and let the water flow out from the inlet hose and the drain hose and collect remaining water in a shallow basin.
 - Close appliance door.
4. Remove the plastic caps on the back of the washing machine.

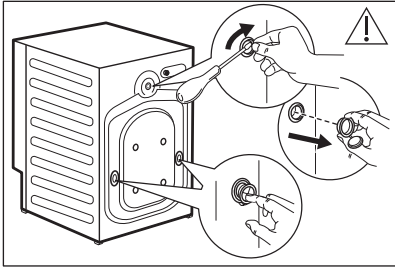

5. Add the three transit bolts, to immobilize the washing group.

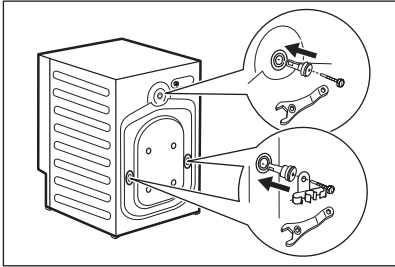

⚠ WARNING!

Before proceeding to point 6. Make sure that appliance door are closed.

6. Gently lay the washing machine on the side of the detergent dispenser.



Put two pieces of styrofoam on the floor and carefully put down the appliance onto it's side. In this position you will have easy assembly and avoid any scratches.

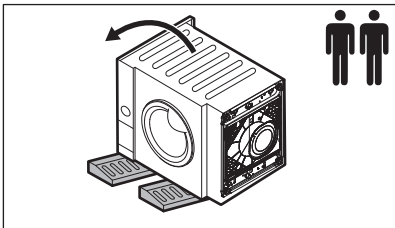

7. Remove the appliance adjustable feet.

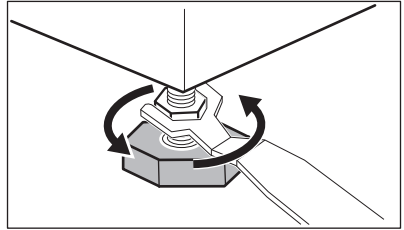

8. Lay the pedestal on the same size and align it under the appliance correctly.

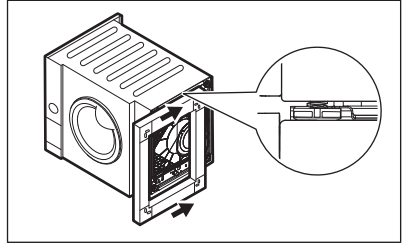

To help in installation the pedestal has indication front-to-back.

9. Screw the brackets using the screwdriver on the pedestal.

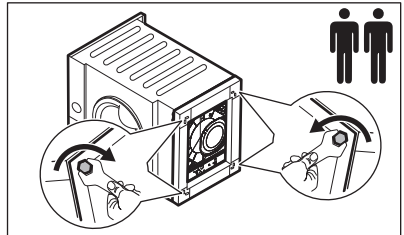

10. Put the pedestal and appliance in vertical position . If necessary, adjust the appliance height. Check if the screws are firmly screwed.

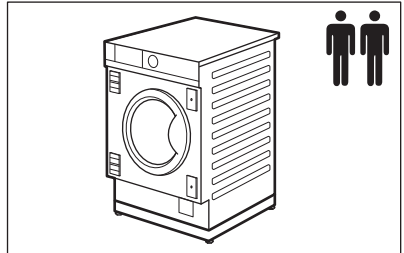

⚠ WARNING!

Do not exceed the maximum height 885mm.

⚠ WARNING!

Remove transit bolts.

11. Put the pedestal/appliance in the desired place and level it by screwing the stand feet. For a perfect levelling, use a spirit level.

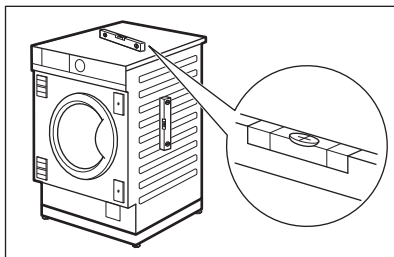

12. Connect the appliance as indicated in the instructions supplied with the appliance.

5. **CH** GUARANTEE

Customer Service Centres

Point of Service

Industriestrasse 10
5506 Mägenwil

Le Trézi 6
1028 Prévèrenge

Via Violino 11
6928 Manno

Morgenstrasse 131
3018 Bern

Langgasse 10
9008 St. Gallen

Am Mattenhof 4a/b
6010 Kriens

Schlossstrasse 1
4133 Pratteln

Comercialstrasse 19
7000 Chur



Spare parts service Industriestrasse 10,
5506 Mägenwil, Tel. 0848 848 111

Specialist advice/Sale Badenerstrasse 587,
8048 Zürich, Tel. 044 405 81 11

Warranty For each product we provide a two-year guarantee from the date of purchase or delivery to the consumer (with a guarantee certificate, invoice or sales receipt serving as

proof). The guarantee covers the costs of materials, labour and travel. The guarantee will lapse if the operating instructions and conditions of use are not adhered to, if the product is incorrectly installed, or in the event of damage caused by external influences, force majeure, intervention by third parties or the use of non-genuine components.

6. ENVIRONMENTAL CONCERNS

Recycle materials with the symbol . Put the packaging in relevant containers to recycle it.



A24595701-A-122023

